

H_JF538-Series

150 fsec typical Phase Jitter

High Frequency Ultra-low jitter

Voltage Controlled Crystal Oscillators (VCXOs)

MERCURY
 Since 1973

H_JF538 series (5.0x3.2x1.4 mm, 8 pads), a member of Mercury QuikXO™ quick-turn XO's, features LVPECL, LVDS, CML or HCSL output logics and femto-second (fsec) RMS phase jitter (151 fsec for LVPECL 644.530 MHz at 3.3V). Short lead time, for both standard and custom frequencies.



Other QuikXO™ products in this family: **G_JF538** series(VCXOs).

General Specifications(¹): at Ta=+25°C

Output Logic Type	LVPECL	LVDS	CML	HCSL	
Frequency Range	150 ~ 2100 MHz	150 ~ 2100 MHz	15 ~ 2100 MHz	150 ~ 700 MHz	
Load	50 ohms into V _{DD} -2V or Thevenin equivalent	100 ohms between OUT and OUTN	50 ohms to V _{DD}	50 ohms to GND	
Power Supply Voltage (V _{DD})	+2.5V ± 10% +3.3V ± 10%	+2.5V ± 10% +3.3V ± 10%	+1.8V ± 5% +2.5V ± 10% +3.3V ± 10%	+1.8V ± 5% +2.5V ± 10% +3.3V ± 10%	
Output "High" Voltage; V _{OH}	V _{DD} - 1.165V min. V _{DD} - 0.8V max.	V _{DD} : 1.4 V typical V _{DD} : 1.6 V max.	V _{DD} - 0.085V min V _{DD} = max.	V _{DD} : 0.66V min. V _{DD} : 1.15V max.	
Output "Low" Voltage; V _{OL}	V _{DD} - 2.0V min. V _{DD} - 1.55V max	V _{DD} : 1.1 V typical V _{DD} : 0.9 V min.	V _{DD} - 0.6V min. V _{DD} - 0.32V min.	V _{DD} : 0.0V min. V _{DD} : 0.15V max.	
Frequency Stability Codes	Frequency stability over operating temp. range	± 25 ppm	± 50 ppm	± 100 ppm	if non-standard , please enter the desired stability after the "C" or "I" for example : "C20" ± 20ppm over -10 to +70°C
	Commercial (-10 to +70°C)	A	B	C	
	Industrial (-40 to +85°C)	D	E	F	
Aging at Ta = 25°C	+3ppm max. first year ; ±2ppm max. per year thereafter				
Duty Cycle (at 50% V _{DD})	50% ±5%	50% ±5%	50% ±5%	50% ±5%	
Rise Time (Tr) / Fall Time (Tf) (20% ↔ 80% waveform)	0.4 nS. max.	0.4 nS. max.	0.4 nS. max.	0.4 nS. max.	
Current Consumption at V _{DD} = 3.3V	100mA typ. 120mA max.	75mA typ. 90mA max.	70mA typ. 85mA max.	94mA typ. 115mA max.	
Current with Output Disabled	99mA typ.	74mA typ.	69mA typ.	93mA typ.	
Start-up Time	5ms typical ; 10 ms max.				
Phase Jitter, rms (12 KHz to 20 MHz)	150 fsec typical , 300 fsec Max.				

H_JF538-Series

150 fsec typical Phase Jitter

**MERCURY**

Since 1973

High Frequency Ultra-low jitter

Voltage Controlled Crystal Oscillators (VCXOs)

Output Enable Function on Pad 1	
OE Control	0.8% of V _{DD} minimum to enable output.
	0.2% of V _{DD} maximum to disable output.
Output Enable Time	2.5 ms max.
Output Disable Time	10 us max.

(*)If you want detailed specifications, please call for details.

Environmental Performance Specifications

Green Requirement	RoHS compliant, Pb (lead) free in accordance with EU Directive 2002/95/EC 6/6 (2002/95/EC) and WEEE (2002/96/EC). Free of halide, cadmium, hexavalent chromium, lead, mercury, PBB's and PBDE's.
Second Level Interconnect	e4
Moisture Sensitivity Level	Level 1 (infinite) according to IPC/JEDEC J-STD-020D.1
Storage temp. range	-55 to +150°C
Humidity	85% RH, 85°C, 48 hours
Fine Leak / Gross Leak	MIL-Std-883, method 1014, condition A / MIL-Std-883, method 1014, condition C
Solderability	MIL-STD-202F method 208E
Reflow	260°C for 10 sec. Two times.
Vibration	MIL-STD-202F method 204, 35G, 50 to 2000 Hz
Shock	MIL-STD-202F method 213B, test condi. E, 1000GG ½ sine wave
Resistance to Solvent	MIL-STD-202, method 215
Temperature Cycling	MIL-STD-883, method 1010
ESD Rating	Human body model (HBM): 2000 V min.
Pad Surface Finish	Gold (0.3 um to 1.0 um) over nickel (1.27 um to 8.89 um)
Weight of the Device	0.045 grams typical

Part Number Format and Example:

Example: 3HPJF5381-E-644.530

3	H	P	JF538	-	1	-	E	-	644.530
Supply Voltage code "3" for 3.3V "25" for 2.5V "18" for 1.8V	"H" : for Crystal oscillators	Output Logic Code "P" : PECL "D" : LVDS "C" : HCSL "Q" : CML	"JF": Product Series. "538": Package size 5.0x3.2x1.4 mm 8 Pad		OE function. "1": OE on pad1. Note 1		Frequency stability code: "A"- "F". See table above.		Frequency(MHz)

Note 1: OE on pad 2 and pad 1 no connection is also available. Please change product series from "JF5381" to "JF5382".



Output OE Function on Pad1

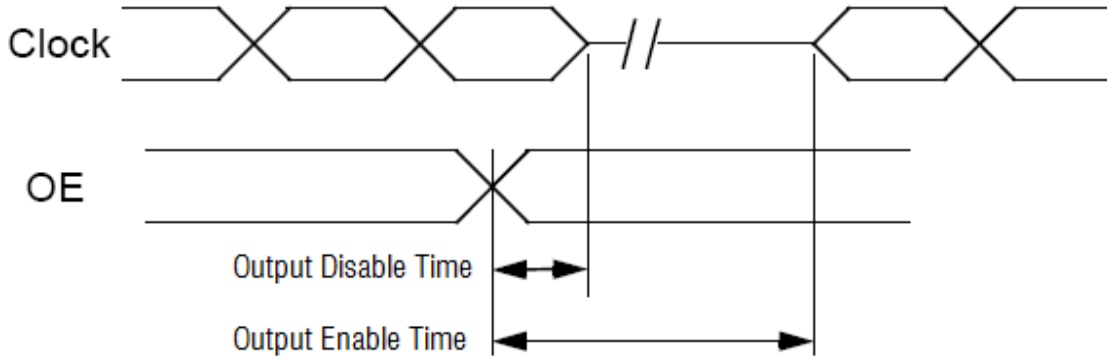

3HPJF538 Phase Noise and Phase Jitter Data (typical), $V_{DD}=+3.3V$, Voltage Control = Ground

	Frequency (MHz)	156.250	491.52	644.530	1480	2100
SSB Phase Noise Data (dBc/Hz Typical)	10 Hz offset	-39	-16	-31	-12	-18
	100 Hz offset	-74	-48	-58	-54	-49
	1 KHz offset	-99	-83	-86	-80	-77
	10 KHz offset	-123	-112	-110	-104	-100
	100 KHz offset	-139	-128	-126	-119	-116
	1 MHz offset	-149	-140	-137	-130	-125
	5 MHz offset	-156	-151	-150	-145	-141
	10 MHz offset	-157	-153	-153	-148	-145
	20 MHz offset	-157	-154	-153	-150	-147
Phase Jitter fsec (12KHz ~ 20 MHz, RMS)		159	155	151	147	163



Phase Noise Plot of 3HPJF5381-E-644.530 MHz, $V_{DD}=+3.3V$, LVPECL, Output Enable $=+3.3V$, $+25^{\circ}C$.

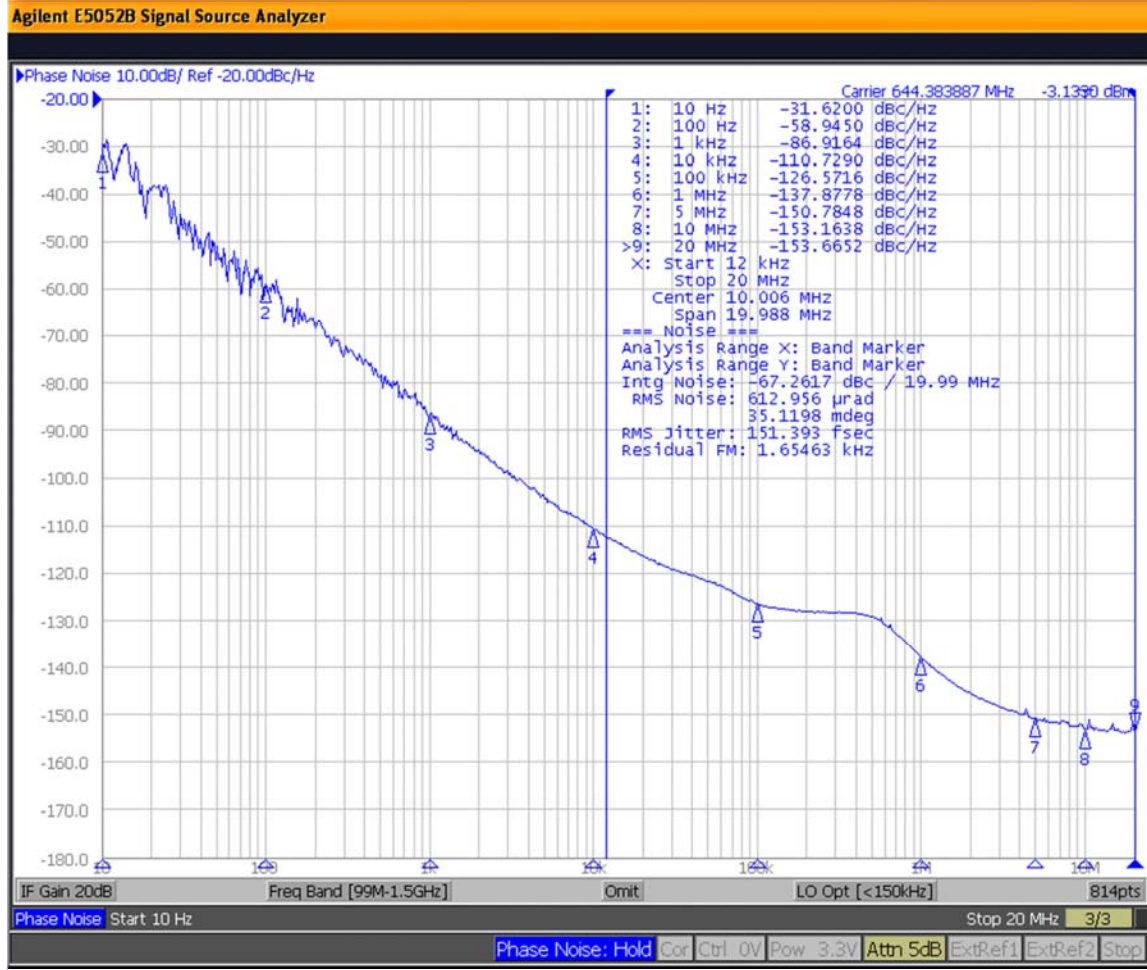

Package Dimensions and Recommended Solder Pad Layout unit: (mm)

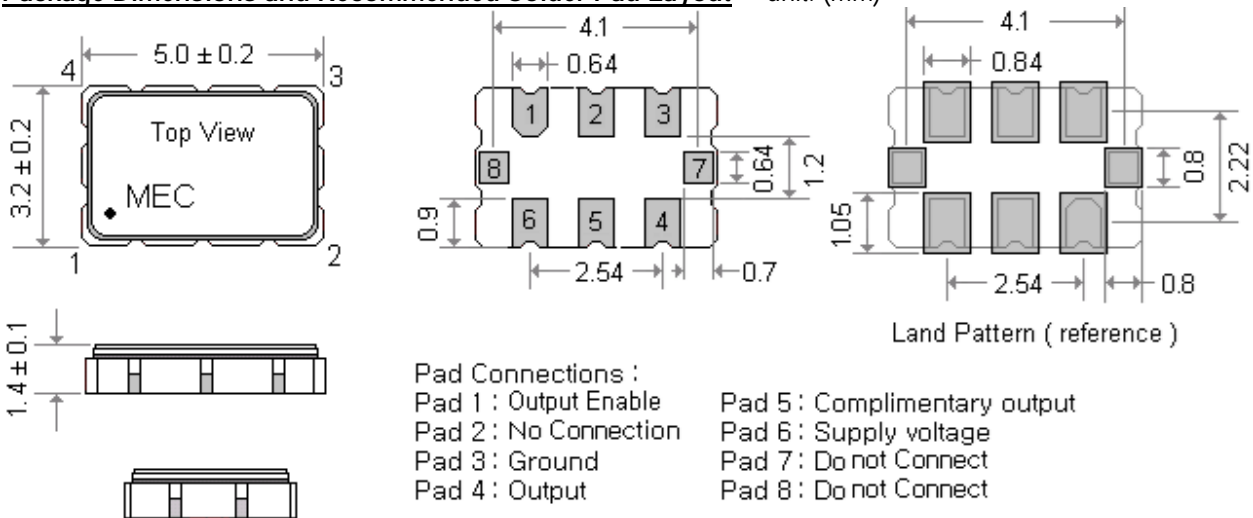



Test Circuits and Output Waveforms

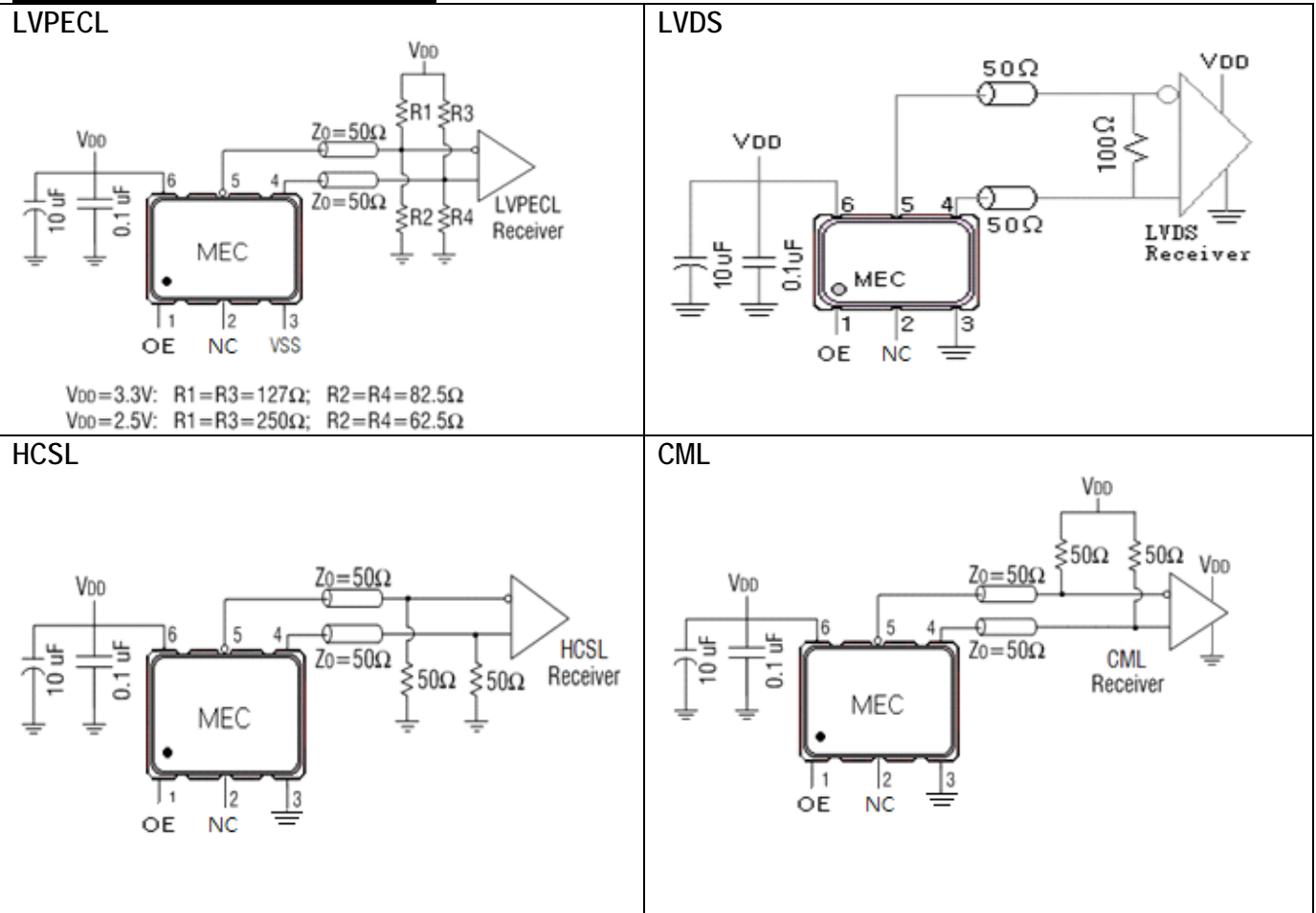

Differential Output Waveforms

Duty cycle = $\left(\frac{T1}{T2}\right) * 100\%$. Measured at 50% VDD

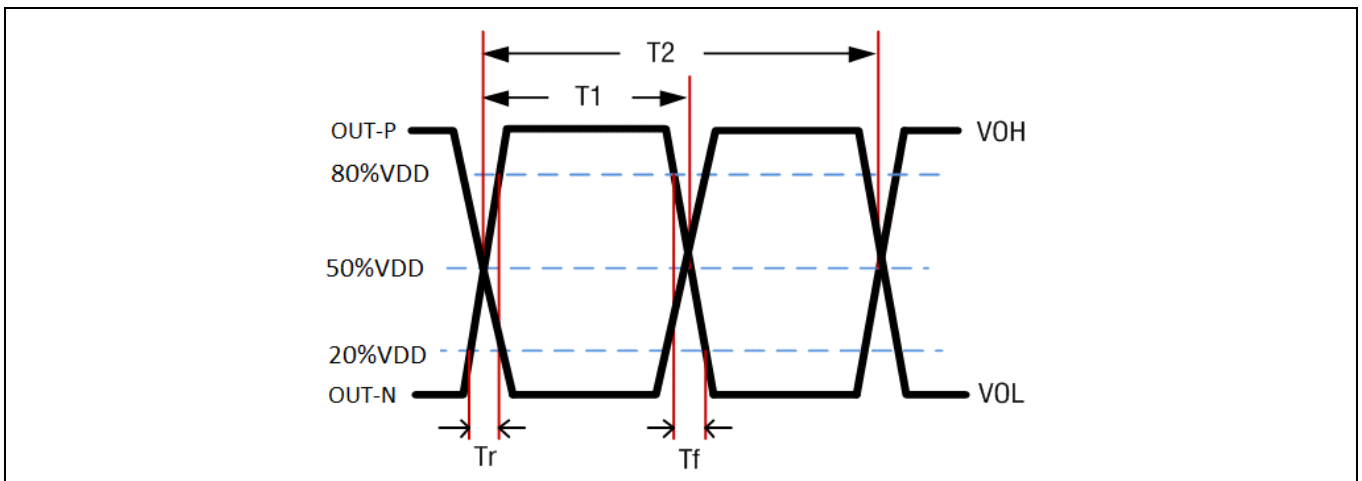



Recommended Solder Reflow Profile (per IPC/JEDEC J-STD-020D.1)

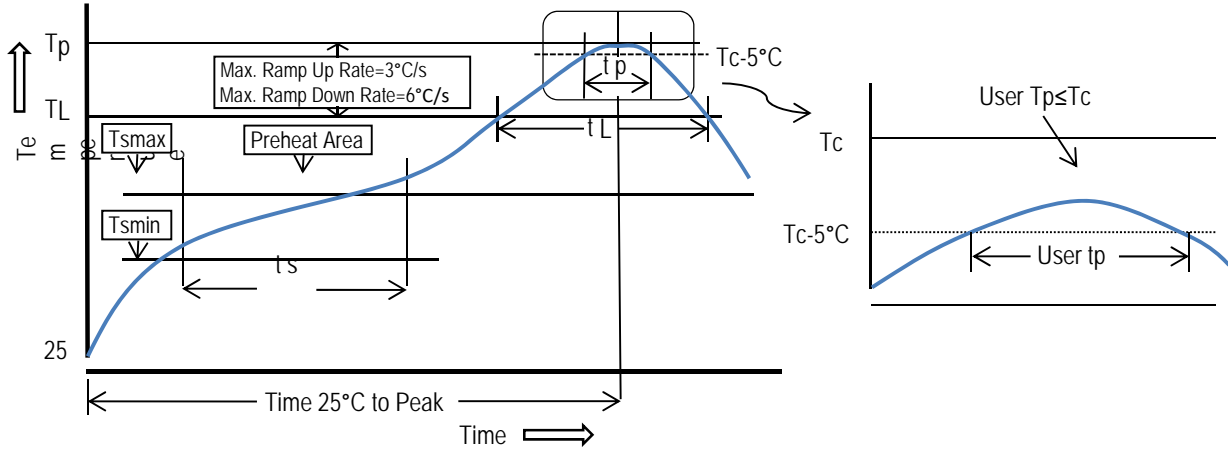

Profile Feature	Sn-Pb Eutectic Assembly	Pb-free Assembly
Preheat/Soak		
- Temperature min. (T _s min.)	100°C	150°C
- Temperature max. (T _s max.)	150°C	200°C
- Time (t _s) (T _s min. to T _s max.)	60 to 120 seconds	60 to 180 seconds
Ramp-up rate (T _L to T _p)	3°C / sec. max.	3°C / sec. max.
Liquidous temperature (T _L)	183°C	217°C
Time (t _L) maintained above T _L	60 to 150 seconds	60 to 150 seconds
Peak package body temperature (T _p)	235°C	260°C
Time (T _p) within 5°C of the classification temperature T _c	10 to 30 seconds	20 to 40 seconds
Ramp-down rate (T _p to T _L)	6°C / second max.	6°C / second max.
Time 25°C to peak temperature	6 minutes max.	8 minutes max.

All temperatures refer to topside of the package, measured on the package body surface.